

---

# TetraCon<sup>®</sup> 700

CONDUCTIVITY MEASURING CELL

---



a xylem brand

**Copyright**

© 2020 Xylem Analytics Germany GmbH  
Printed in Germany..

## TetraCon® 700 - Contents

<b>1</b>	<b>Overview</b>	<b>4</b>
1.1	Structure of the TetraCon® 700 conductivity measuring cell	4
1.2	Recommended fields of application	5
1.3	Variants and identification	5
<b>2</b>	<b>Safety</b>	<b>6</b>
2.1	General information on safety	6
2.2	Authorized use	6
2.3	General safety instructions	7
<b>3</b>	<b>Commissioning</b>	<b>9</b>
3.1	Scope of delivery	9
3.2	Installation	9
3.2.1	Connection to the measuring transmitter	9
<b>4</b>	<b>Measuring / Operation</b>	<b>10</b>
4.1	Measuring	10
4.2	Application-dependent settings	11
<b>5</b>	<b>Maintenance, cleaning, disposal</b>	<b>12</b>
5.1	Maintenance	12
5.2	Cleaning	12
5.3	Disposal	12
<b>6</b>	<b>What to do if ...</b>	<b>13</b>
<b>7</b>	<b>Replacement parts and accessories</b>	<b>14</b>
<b>8</b>	<b>Technical data</b>	<b>15</b>
8.1	General features	15
8.2	Electrical data	16
8.3	Measurement conditions	18
8.4	Characteristic data on delivery	18

# 1 Overview

## 1.1 Structure of the TetraCon® 700 conductivity measuring cell

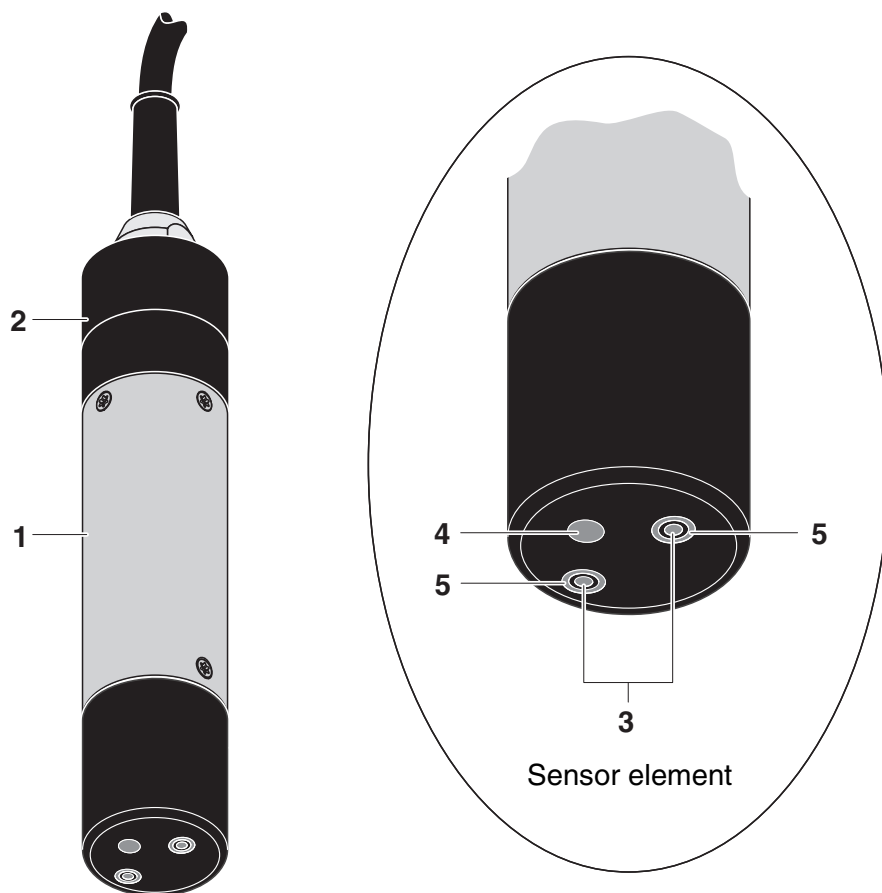

Fig. 1-1 Structure of the TetraCon® 700 conductivity measuring cell

1	Shaft
2	Closing head with protective ring
3	Voltage electrodes
4	Temperature sensor
5	Current electrodes (ring)

## 1.2 Recommended fields of application

The TetraCon® 700 conductivity measuring cell is suitable for stationary measurements in water/wastewater applications.

### Characteristics

The principle of the measurement method enables to avoid influences from primary or secondary polarization effects, which ensures a high degree of measuring accuracy.

The modern epoxy casting technique reduces the danger of breaking the conductivity measuring cell in rough industry use.

## 1.3 Variants and identification

### Instrument identification

The instrument designation is printed on the plug-sided end of the cable. The series number is engraved in the closing head. Have these designations ready in case of queries to the WTW service department.

## 2 Safety

### 2.1 General information on safety

These safety instructions contain all instructions that have to be followed for a safe operation of the TetraCon® 700 conductivity measuring cell. Before starting any work with the TetraCon® 700, carefully read the safety instructions and strictly follow all protective measures mentioned.

Always store and make available these safety instructions together with the operating manual in the vicinity of the place of installation.

#### General safety instructions

Safety instructions in this operating manual can be recognized by the warning symbol (triangle) in the left column. The signal word (e.g. "Caution") indicates the danger level:



#### Warning

indicates instructions that must be followed precisely in order to prevent serious dangers to persons.



#### Caution

indicates instructions that must be followed precisely in order to avoid slight injuries or damage to the instrument or the environment.

#### Other labels



#### Note

indicates notes that draw your attention to special features.



#### Note

indicates cross-references to other documents, e.g. operating manuals.

### 2.2 Authorized use

Authorized use of the TetraCon® 700 consists of stationary conductivity measurement in the following areas:

- Water and wastewater
- Environment
- Industry.

Please observe the technical specifications according to chapter 8 TECHNICAL DATA. Only operation according to the instructions given in this operating manual is considered to be authorized.

Any other use is considered to be **unauthorized**. Unauthorized use invalidates any claims with regard to the guarantee.

### Function and operational safety

## 2.3 General safety instructions

The conductivity measuring cell left the factory in a safe and secure technical condition.

The smooth functioning and operational safety of the conductivity measuring cell can only be guaranteed if the generally applicable safety measures and the specific safety instructions in this operating manual are followed during operation.

The smooth functioning and operational safety of the conductivity measuring cell can only be guaranteed under the environmental conditions that are specified in chapter 8 TECHNICAL DATA.

The specified temperature (chapter 8 TECHNICAL DATA) must be maintained during the application and transport of the conductivity measuring cell. Protect the conductivity measuring cell, particularly against frost or overheating.

**Safe operation**

If safe operation is no longer possible, the conductivity measuring cell must be taken out of operation and secured against inadvertent operation.

Safe operation is no longer possible if the conductivity measuring cell:

- has been damaged in transport
- has been stored under adverse conditions for a lengthy period of time
- is visibly damaged
- no longer operates as described in this manual.

If you are in any doubt, contact the supplier of your conductivity measuring cell.

**Obligations of the operator**

The operator of the conductivity measuring cell must ensure that the following rules and regulations are followed when dealing with hazardous substances:

- EC directives for protective labor legislation
- National protective labor legislation
- Safety regulations
- Safety data sheets of the chemical manufacturer.

**Caution**

**All changes of the TetraCon® 700 that exceed the work described in this operating manual are not allowed. Repair work may only be carried out by WTW Weilheim.**



## 3 Commissioning

### 3.1 Scope of delivery

- TetraCon® 700
- The conductivity measuring cell is equipped with protective caps
- Operating manual.

### 3.2 Installation

#### 3.2.1 Connection to the measuring transmitter

The TetraCon® 700 connection cable has a cable plug to be connected to the Cond input socket of a measuring transmitter. It is connected to the terminal strip of a measuring transmitter without a Cond input socket via the ADA/AMPH-LF adapter (see chapter 7 REPLACEMENT PARTS AND ACCESSORIES).

For detailed information please refer to the operating manual of the measuring transmitter.

## 4 Measuring / Operation

### 4.1 Measuring



#### Warning

Contact with the sample can lead to danger to the user!  
Depending on the type of sample, suitable protective measures must be taken (protective clothing, protective goggles, etc.).

#### Minimum immersion depth

Please observe the minimum immersion depth of the conductivity measuring cell (> 30 mm).

#### Spacing

Please make sure that at the electrodes, the conductivity measuring cell is surrounded by a clearance of at least 5 cm at the base and sides (boundary fields).

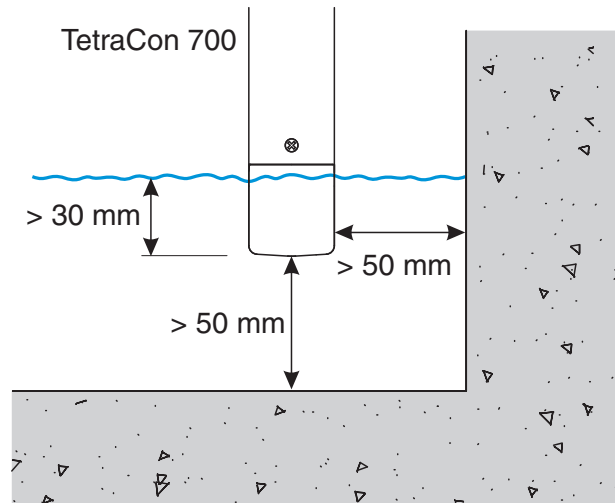

#### Measuring at a narrow location

If the clearance is less than that, the cell constant changes. This leads to inexact measurement results. Normally, measuring transmitters have a correction function that can compensate for this influence. This procedure determines a new cell constant for the system consisting of conductivity measuring cell + measuring environment. For more detailed information, refer to section 4.2 APPLICATION-DEPENDENT SETTINGS.



#### Note

Normally, the conductivity measuring cell does not age. Special measuring media (e.g. strong acids and bases, organic solvents) or temperatures that are too high may considerably reduce its lifetime or lead to damage. No warranty claims can be made for mechanical damage or any failure caused by these types of measuring media.

## 4.2 Application-dependent settings

The TetraCon® 700 conductivity measuring cell is long-term stable. The conductivity measuring cell is immediately ready for operation for its authorized use in water/wastewater applications.

### Adapting the cell constant to the installation location

In the case of special installation conditions, it may be necessary to adapt the cell constant (due to the influence of the measuring environment, e.g. of boundary fields).

In chapter 6 WHAT TO DO IF ... of this operating manual you will find the correct values to set for some products of the WTW accessory program that require a correction of the cell constant (if it is possible to give fixed values at all). If necessary, special installation recommendations for the TetraCon® 700 can be found in the accessory operating manual.



#### Note

Details on how to determine and set the cell constant can be taken from the operating manual of the measuring transmitter.

## 5 Maintenance, cleaning, disposal

### 5.1 Maintenance

The TetraCon® 700 conductivity measuring cell does not require maintenance.

### 5.2 Cleaning



#### Warning

**Contact with the measuring solution or cleaning solution can endanger the user! Take protective measures suitable for the kind of measuring solution or cleaning solution (protective clothes, eye protectors etc.).**

If the conductivity measuring cell is heavily contaminated, this can affect the measuring accuracy. Therefore, we recommend cleaning the conductivity measuring cell regularly according to visual checks. Especially before measuring low conductivity values, we recommend to clean the measuring cell thoroughly.

#### Cleaning procedure

Contamination	Cleaning agents	Reaction time at room temperature
Water-soluble substances	Tap water	any
Slurry and loosely adhering dirt or biological films	Soft brush, warm tapwater with washing-up liquid	any
Fats and oils	<ul style="list-style-type: none"> <li>– Warm water and household washing-up liquid</li> <li>– In case of heavy contamination: methylated spirit</li> </ul>	<ul style="list-style-type: none"> <li>– Any</li> <li>– 5 minutes maximum</li> </ul>
Lime and hydroxide deposits	Acetic acid (10 %)	any

### 5.3 Disposal

We recommend to dispose of the conductivity measuring cell as electronic waste.

## 6 What to do if ...

### Measurement delivers no or wrong measured values

Cause	Remedy
– Conductivity measuring cell not correctly connected	– Check connection to measuring transmitter
– Cable damaged	– Check cable. If it is defective, send conductivity measuring cell to WTW
– Measuring range exceeded	– Select larger measuring range or set automatic selection of the measuring range

### Measurement provides implausible measured values

Cause	Remedy
– Conductivity measuring cell is heavily contaminated	– Clean the conductivity measuring cell
– Boundary fields not observed	– At the electrodes, the conductivity measuring cell must be surrounded by a clearance of at least 5 cm at the base and sides. Otherwise, the cell constant will change (see section 4.1 MEASURING)
– Electrodes damaged	– Return the measuring cell
– System setting incorrect	– Correct the system setting
– Measuring range exceeded	– Observe the range of application
– The measuring cell was installed in a flow-through device and the boundary field is not sufficient	<ul style="list-style-type: none"> <li>– Set the cell constant to the value of the installed position (if known)</li> <li>– If the cell constant of the measuring cell in the installed position is not known, Adjust the measured value to the nominal value of a measuring solution (see operating manual of the measuring transmitter)</li> </ul>

## 7 Replacement parts and accessories

Adapter	Model	Order no.
	ADA/AMPH-LF	303 215

**Note**

Information on further accessories is given in the WTW catalog and on the Internet.

## 8 Technical data

### 8.1 General features

<b>Measuring range</b>	10 µS/cm ... 1000 mS/cm at 0 °C ... + 50 °C	
<b>Measuring principle</b>	Four-electrodes measurement	
<b>Temperature sensor</b>	Integrated NTC 30 (30 kΩ / 25 °C)	
<b>Dimensions</b>	Length	196 mm (without screwed cable gland)
	Shaft diameter	40 mm
<b>Weight</b>	approx. 660 g (without sensor connection cable)	
<b>Material</b>	Sensor head	PVC, epoxy (filling material)
	Electrodes, housing of the temperature sensor	Graphite
	Shaft	Stainless steel 1.4571
	Closing head	POM
	Protection ring	POM
	Cable screw joint	Stainless steel 1.4571
	Cable coating	PUR
<b>Connection cable</b>	Length	Depending on variant: – 1.5 m – 7.0 m – 15.0 m – Special lengths on customer request up to 100 m
	Diameter	8.8 mm
	Smallest allowed bend radius	Permanent bend: 180 mm Short time bend: 90 mm
	Connection	Screw plug, 7 poles (IP 65)

<b>Guidelines and norms used</b>	General safety	– EN 61010-1 – UL 3111-1 – CAN/CSA C22.2 No. 1010.1
<b>Test certificates</b>	UL, cUL	

## 8.2 Electrical data



### Caution

All voltages must be protective low voltages or safety extra low voltages without hazard of contact according to E 61010-1 or UL 3111-1.

### Wiring diagram

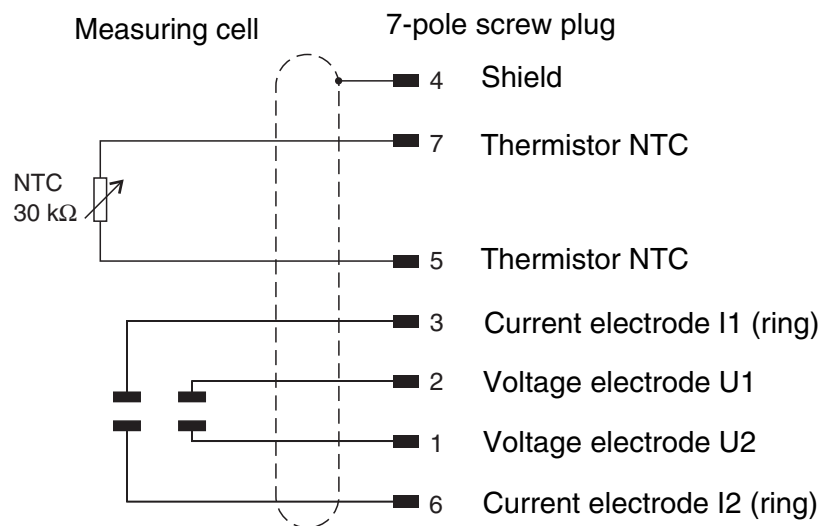

Pin assignment	Pin	Assignment	Wire color	Max. voltage	Max. current
	1	U2	Yellow	---	---
	2	U1	Gray	---	---
	3	I1	Pink	1 V	5 mA
	4	Shield	Transparent	---	---
	5	NTC	Brown	3.5 V	0.15 mA
	6	I2	Green	1 V	5 mA
	7	NTC	White	3.5 V	0.15 mA



Plug from the front:

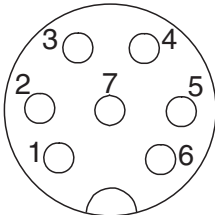

### 8.3 Measurement conditions

<b>Temperature range</b>	Measuring medium	0 °C ... + 50 °C
	Storage/transport	- 5 °C ... + 65 °C (storage in air recommended)
<b>Immersion depth</b>	min. 30 mm	
<b>Operating position</b>	any	
<b>Approach flow</b>	not required	
<b>Pressure resistance</b>	Conductivity measuring cell including connection cable:	
	Max. admissible overpressure	10 <sup>6</sup> Pa (10 bar)
	Type of protection	IP 68 (106 Pa or 10 bar)
	7-pole screw plug:	
	Type of protection	IP 65

The TetraCon® 700 meets the requirements according to article 3(3) of the directive, 97/23/EC ("pressure equipment directive").

### 8.4 Characteristic data on delivery

<b>Temperature measurement</b>	Sensor accuracy	± 0.2 K
	Response time	t <sub>90</sub> (90 % of the final value display after) < 60 s t <sub>95</sub> (95 % of the final value display after) < 120 s
<b>Cell constant</b>	In free solution, i.e. base and side clearance > 5 cm	K = 0.917 cm <sup>-1</sup> ± 1.5 %
	In a flow-thru system, e.g. EBST 700-DU/N	K = 0.933 cm <sup>-1</sup> ± 1.5 %



# What can Xylem do for you?

We're a global team unified in a common purpose: creating innovative solutions to meet our world's water needs. Developing new technologies that will improve the way water is used, conserved, and re-used in the future is central to our work. We move, treat, analyze, and return water to the environment, and we help people use water efficiently, in their homes, buildings, factories and farms. In more than 150 countries, we have strong, long-standing relationships with customers who know us for our powerful combination of leading product brands and applications expertise, backed by a legacy of innovation.

**For more information on how Xylem can help you, go to [xylem.com](http://xylem.com).**



## **Service and Returns:**

Xylem Analytics Germany

Sales GmbH & Co. KG

WTW

Dr.-Karl-Slevogt-Str. 1

82362 Weilheim

Germany

Tel.: +49 881 183-325

Fax: +49 881 183-414

E-Mail [wtw.rma@xylem.com](mailto:wtw.rma@xylem.com)

Internet: [www.WTW.com](http://www.WTW.com)



Xylem Analytics Germany GmbH

Dr.-Karl-Slevogt-Str. 1

82362 Weilheim

Germany